

Documentation

***2/2 way pilot operated valve
with assisted lift, G 3/8" - G 1"
- Type M ... 24V=, M ... 220V -***



1. Directory

1. Directory	1
2. Technical specifications	2
3. Scheme of components	2
4. Valve types	2
5. Description	3
6. Cautions	3
7. Installation	3
8. Maintenance	4
9. Dimensions and weights	4
10. Coils for solenoid valves	6

2. Technical specifications

Media: water, oil, air
Media temperature: -10°C ... +90°C
Body material: brass
Coil consumption: AC 18 VA, AC 36 VA (inrush), DC 14 W
Protection class: IP 65 (with connector)
 Speed control screw as standard for type M 210 24V=

2/2 Wege-Magnetventile aus Messing

Werkstoffe: Körper: Messing, Innenteile: Messing/Edelstahl, Dichtung: NBR (Typen mit G 1/8" und G 1/4": Viton)
Temperaturbereich: -10°C bis +85°C (Typen mit G 1/8" und G 1/4": -10°C bis max. +130°C), Umgebung: -10°C bis max. +50°C
Medium: Druckluft, neutrale Gase, Wasser, neutrale dünnflüssige Medien, Heizöl, andere Medien auf Anfrage
Spannungen: Standard: 24V= oder 230V 50/60Hz, auf Wunsch: andere Spannungen siehe Bestellbeispiel
Schutzart: IP 65
☞ Optional: Viton-Dichtung (-10°C bis max. +130°C) -V, EPDM-Dichtung für Luft und Heißwasser (-10°C bis max. +120°C) -EP, EX-geschützt** -EX



Typ M 218 und M 214
Typ MO 218 und MO 214

Typ	Typ	Gewinde	DN	L	Arbeitsdruck (bar)		kv-Wert ¹⁾
24V =	230V 50/60 Hz				DC	AC	
stromlos geschlossen (NC)							
M 218 24V=	M 218 220V	G 1/8"	2,2	38	0 - 13	0 - 18	2,4 l/min
M 214 24V=	M 214 220V	G 1/4"	2,2	38	0 - 13	0 - 18	2,4 l/min
M 238 24V=	M 238 220V	G 3/8"	13	67	0,3 - 16 ²⁾	0,3 - 16 ²⁾	55 l/min
M 2380 24V=	M 2380 220V	G 3/8"	15	75	0 - 6	0 - 16	60 l/min
M 212 24V=	M 212 220V	G 1/2"	13	67	0,3 - 16 ²⁾	0,3 - 16 ²⁾	63 l/min
M 2120 24V=	M 2120 220V	G 1/2"	15	75	0 - 6	0 - 16	65 l/min
M 234 24V=	M 234 220V	G 3/4"	21	82	0,3 - 16 ²⁾	0,3 - 16 ²⁾	90 l/min
M 2340 24V=	M 2340 220V	G 3/4"	15	85	0 - 6	0 - 16	80 l/min
M 210 24V=	M 210 220V	G 1"	25	96	0,3 - 16 ²⁾	0,3 - 16 ²⁾	216 l/min
M 2100 24V=	M 2100 220V	G 1"	15	85	0 - 5	0 - 16	85 l/min
M 2114 24V=	M 2114 220V	G 1 1/4"	40	140	0,5 - 16 ²⁾	0,5 - 16 ²⁾	370 l/min
M 21140 24V=	M 21140 220V	G 1 1/4"	40	140	0 - 10	0 - 10	366 l/min
M 2112 24V=	M 2112 220V	G 1 1/2"	40	140	0,5 - 16 ²⁾	0,5 - 16 ²⁾	400 l/min
M 21120 24V=	M 21120 220V	G 1 1/2"	40	140	0 - 10	0 - 10	416 l/min
M 220 24V=	M 220 220V	G 2"	50	168	0,5 - 16 ²⁾	0,5 - 16 ²⁾	540 l/min
stromlos geöffnet (NO)							
MO 218 24V=	MO 218 220V	G 1/8"	2,5	40	0 - 16	0 - 18	3,4 l/min
MO 214 24V=	MO 214 220V	G 1/4"	3	40	0 - 8	0 - 15	4,5 l/min
MO 238 24V=	MO 238 220V	G 3/8"	13	67	0,3 - 16 ²⁾	0,3 - 16 ²⁾	55 l/min
MO 212 24V=	MO 212 220V	G 1/2"	13	67	0,3 - 16 ²⁾	0,3 - 16 ²⁾	63 l/min
MO 234 24V=	MO 234 220V	G 3/4"	21	82	0,3 - 16 ²⁾	0,3 - 16 ²⁾	90 l/min
MO 210 24V=	MO 210 220V	G 1"	27,5	96	0,3 - 16 ²⁾	0,3 - 16 ²⁾	216 l/min
MO 2100 24V=	MO 2100 220V	G 1"	25	95	0 - 16	0 - 16	216 l/min
MO 2114 24V=	MO 2114 220V	G 1 1/4"	40	140	0,5 - 16 ²⁾	0,5 - 16 ²⁾	370 l/min
MO 2112 24V=	MO 2112 220V	G 1 1/2"	40	140	0,5 - 16 ²⁾	0,5 - 16 ²⁾	400 l/min
MO 220 24V=	MO 220 220V	G 2"	50	168	0,5 - 16 ²⁾	0,5 - 16 ²⁾	540 l/min

** bitte Schutzart angeben, nur NC-Ventile

¹⁾ Wasserdurchfluss bei +20°C, 1 bar Druck am Ventileingang, freier Auslauf.

Durchfluss für Luft [l/min] ≈ 13,4 · kv · P_{Eingang} / P_{Ausgang} (P_{Eingang} und P_{Ausgang} sind Absolutwerte in bar).



²⁾ Servogesteuerte Ventile benötigen zum Öffnen oder Schließen eine Druckdifferenz zwischen Ventileingang und -ausgang. Die Druckdifferenz wird als Mindestdruck angegeben. Entsteht im Ventil ein Druckausgleich, eventuell dadurch, dass am Ventil ausgang kein oder nur wenig Medium verbraucht wird, funktioniert das Ventil nicht mehr (es öffnet oder schließt nicht zuverlässig).



Diese Ventile werden grundsätzlich mit Spule und Stecker ausgeliefert!

Bestellbeispiel: M 218 ***

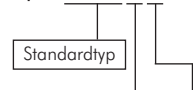

Kennzeichen der Optionen

Viton-Dichtung -V
 EPDM-Dichtung -EP
 EX-geschützt** -EX

Verfügbare Spannungen

24V= (Standard) -24V=
 230V 50/60Hz (Standard) -220V
 12V= -12V=
 48V= -48V=
 24V 50/60Hz -24VAC
 115V 50/60Hz²⁾ -110V
 48V 50/60Hz -48V

3. Scheme of components

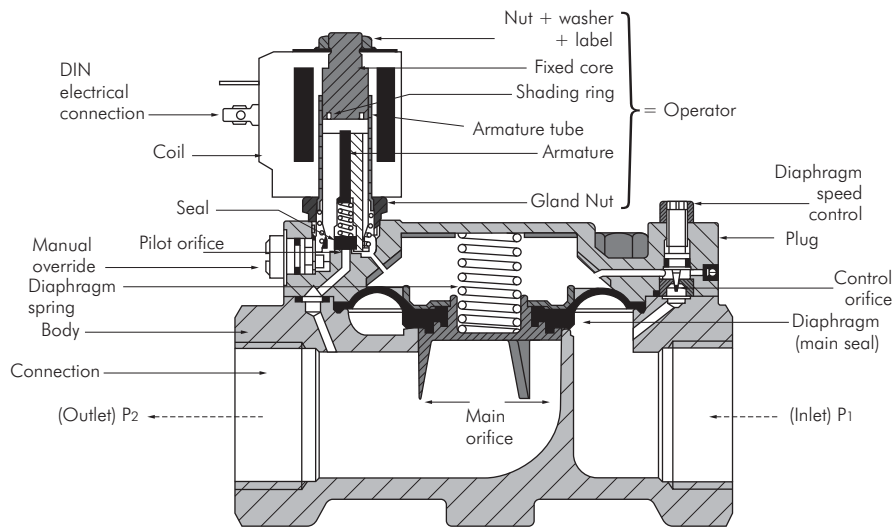

Robust construction for industrial use Long life	—————>	High reliability
Stainless steel operators with low residual magnetism according to DIN 1.4105 and AISI 430F	—————>	Corrosion resistance High performance
High quality seal materials NBR, FKM, EPDM, PTFE, Sigodur (filled PTFE), Ruby	—————>	Maximum compatibility with fluids
Fully interchangeable coils with a wide range of AC and DC voltages	—————>	High flexibility with reduced stock
Coils orientability at 360°	—————>	Easy and quick installation

4. Valve types

Direct acting solenoid valves 2/2 and 3/2 way NC or NO

The supply coil electrically generates a magnetic force that attracts the armature, which contains the seat that acts upon a passage orifice. The armature, rising, lets the fluid pass. The range of operating pressures depends directly on the attraction force of the coil. Average response time 5 ÷ 25 ms.



Pilot operated solenoid valves 2/2 way NC or NO

This solenoid valve uses the force of the fluid to operate the valve via a suitable integral pilot valve. The inlet pressure must always be at least the same as the minimum ΔP figure shown on the data sheets. Using the same coils as direct acting valves much higher fluid volumes and pressures can be controlled with this solenoid valve. Average response time 50 ÷ 500 ms.

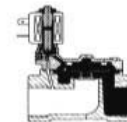

Pilot operated solenoid valves with assisted lift 2/2 way NC

These solenoid valves are a combination of the pilot operated valves and the direct acting valves. The armature is mechanically connected to the diaphragm on which there is a pilot orifice. With minimal pressures the solenoid valve acts like a direct acting valve. Total opening as well as full flow do not occur at low pressures. With higher pressures it works as a pilot operated valve with full opening. Average response time 50 ÷ 500 ms.

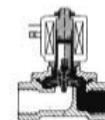

5. Function types

2/2 way function indicates valves with inlet and outlet connections, whilst valves with 3/2 way functions have 3 connections and 2 flow passages. One orifice always remains open and one closed. Connections and flow direction are shown in the symbols on each technical data sheet (DIN-ISO 1219).

At rest valves can be either normally closed (NC) or normally open (NO):

- Normally closed (NC): the valve opens when the coil is energised.
- Normally open (NO): the valve closes when the coil is energised.

5. Description

Direct acting solenoid valves and diaphragm or piston pilot operated solenoid valves; Body in forged brass or stainless steel; Class F or class H coils; Electrical connections for DIN EN 175301-803 connector; Protection class: IP 65 (with properly installed plug).

6. Cautions

- This product will contain fluid under pressure. Improper use could be dangerous and damage people and things. This product is not a safety device and must not be used as sole device to prevent the over-pressure of some parts of the plant or the containment of dangerous fluids.
 - Read carefully the manufacturer's instructions before installation, start-up and maintenance.
 - Check for the operating conditions on product label and on the technical documents (pressure, temperature, fluid, electrical supply) before installation, start-up and maintenance.
 - Respect the flow direction indicated with an arrow on the valve body: the flow is from port 1 for 2-way valves and from port 2 for 3-way valves. Valves with an arrow printed on the body can work only in that direction.
 - Before disconnecting or disassembling the valve, make sure that there is no pressure inside the tubing or inside the valve itself.
 - Use only original spare parts supplied by the manufacturer.
 - Do not exceed the limits of pressure, temperature and voltage given by the manufacturer and shown on the product label and on the technical documents.
 - Do not remove labels neither from the valve nor from the coil.
 - Check for compatibility between the fluid and the material of the valve before installation and start-up. In case of doubt, please contact the manufacturer.
 - The coil provides the basic insulation only. Install the product in a protected place to prevent electric shocks.
 - Do not touch the energized coil: risk of high temperature.
 - Always connect the coil's earth terminal to ground. Do not use the tubes for conveying fluid to ground electrical devices.
 - Valve must be supported only by the provided connections, where foreseen. Tubes must not transmit static load or vibrations to the valve. Do not use the valve as a support for other equipment or fittings.
 - The fixing holes, where provided, or anything else on the valve body must not be modified. Whilst tightening or unscrewing the valve must be held or revolved only and exclusively by the hexagon or the frame set. The use of other components such as coil, armature or cover could cause irreparable damage to the valve.
 - Care should be taken to prevent foreign bodies – dirt or material chips – from entering the valve during the assembly phase. In those installation where impurities or deposit of various types may infiltrate the fluid, the installation of a suitable filter is recommended.
 - Use suitable seal material on the valve threads. In those installation where liquid cement are used, it is important to prevent them from entering the valve and block the movement.
 - Do not shut the holes of pilot operated solenoid valve circuit
 - The coil should not be energized before being installed on the valve or without the armature assembly inside since this could cause make it burn out or break.
-

7. Installation

- Read carefully the manufacturer's instructions before installation and start-up.
- Follow the manufacturer's instruction before installation and start-up.
- The valve can operate in any position. The vertical installation (with upside coil) is highly recommended to avoid any impurity fall into the plug and to extend the life of the valve.
- The coil provides the basic insulation only. Install the product in a protected place to prevent electric shocks, unless the electrical supply voltage is a very low safety voltage.
- Coils can be rotated on their axis by loosening the coil nut and tightening it again at 0.5 Nm.
- The coil temperature normally increases during operation (this is a normal condition). Irregular overheating will cause smoke and smell of burning. In this case the power supply must be immediately stopped. Install the valve far from sources of heat and in environments where the heat produced by the coil can be easily dissipated.
- It is important to respect the flow direction, the pressure and the technical data on the label.

8. Maintenance

- Refer to figure 1 (pilot operated solenoid valve) and figure 2 (direct acting solenoid valve) to disassemble the internal components of the valve.
- Clean the internal parts disassembling the valve (figure 1 and 2); remove dirt and dust and then reassemble all the components.
- When purchasing spare parts, ALWAYS mention the model and the code of the valve (indicated on the valve plate) and the date code (mentioned on the coil label).

The disposal of the product must be carried out as per EEC directives 75/442, 76/403, 78/319, further modifications as well as possible local regulations.

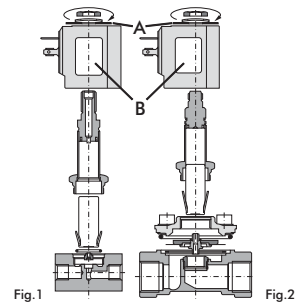

9. Dimensions and weights

9.1. G 1/8" - G 1/4"

Typ 24V =	Typ 230V 50/60 Hz	Gewinde G	A	B	C	D	Gewicht kg
M 218 24V=	M 218 220V	G 1/8"	38	62,5	17	14,5	0,19
M 214 24V=	M 214 220V	G 1/4"	38	62,5	17	14,5	0,18
MO 218 24V=	MO 218 220V	G 1/8"	40	77,5	32	11,0	0,26
MO 214 24V=	MO 214 220V	G 1/4"	40	77,5	32	11,0	0,26

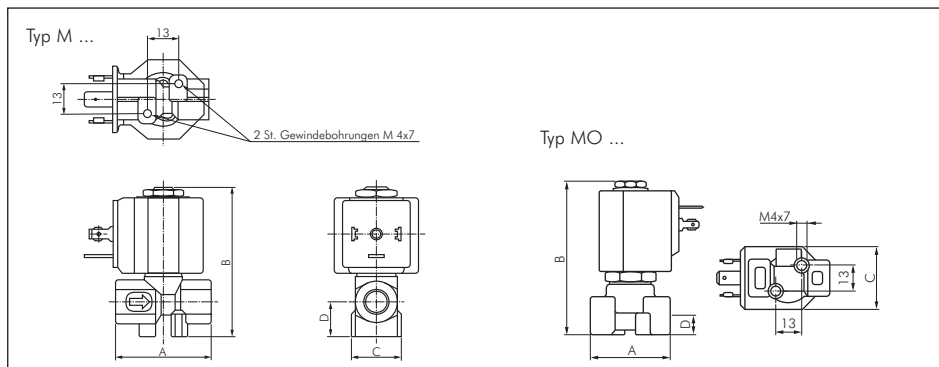

9.2. G 3/8" - G 1"

Typ 24V =	Typ 230V 50/60 Hz	Gewinde G	A	B	C	D	Gewicht kg
M/MO 238 24V=	M/MO 238 220V	G 3/8"	67	90	44	15	0,4
M/MO 212 24V=	M/MO 212 220V	G 1/2"	67	90	44	15	0,4
M/MO 234 24V=	M/MO 234 220V	G 3/4"	82	105	50	20,25	0,6
M/MO 210 24V=	M/MO 210 220V	G 1"	96	115	70	23	1,2

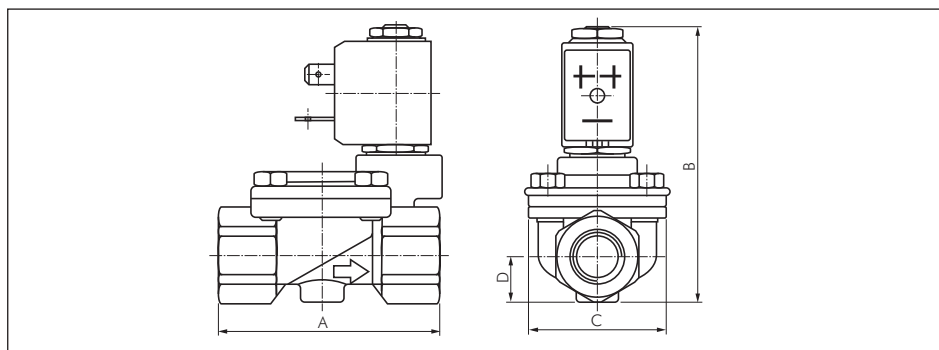

9.3. G 1 1/4" - G 2"

Typ 24V =	Typ 230V 50/60 Hz	Gewinde G	A	B	C	D	Gewicht kg
M/MO 2114 24V=	M/MO 2114 220V	G 1 1/4"	140	140	96	31	2,8
M/MO 2112 24V=	M/MO 2112 220V	G 1 1/2"	140	140	96	31	2,8
M/MO 220 24V=	M/MO 220 220V	G 2"	168	158	112	39	3,9

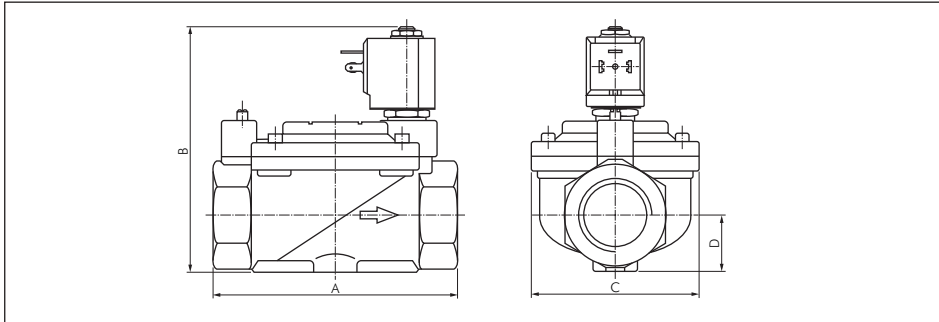

9.4. G 3/8" - G 1"

Typ 24V =	Typ 230V 50/60 Hz	Gewinde G	A	B	C	D	Gewicht kg
M 2380 24V=	M 2380 220V	G 3/8"	75	108	53	14	0,5
M 2120 24V=	M 2120 220V	G 1/2"	75	108	53	14	0,5
M 2340 24V=	M 2340 220V	G 3/4"	85	108	52	21,5	0,8
M/MO 2100 24V=	M/MO 2100 220V	G 1"	85	108	52	21,5	0,7

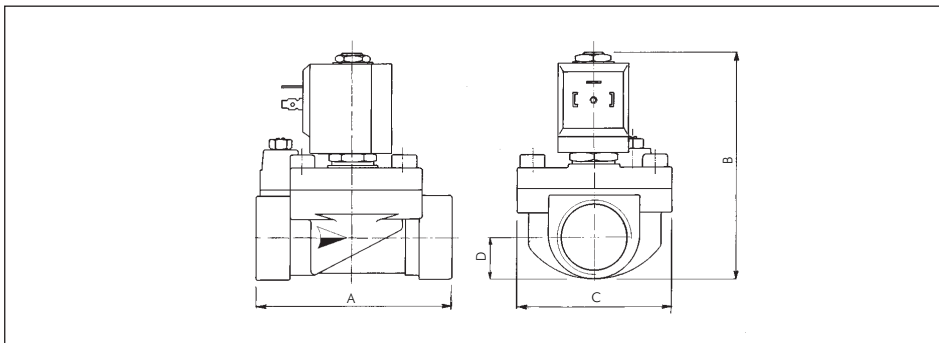

9.5. G 1 1/4" - G 1 1/2"

Typ 24V =	Typ 230V 50/60 Hz	Gewinde G	A	B	C	H	K	L	M	N	SW	†	Pg	Gewicht kg
MO 2100 24V=	MO 2100 220V	G 1"	70	35x35	66	145	122	96	50	10	41	16	11	1,8
M 21140 24V=	M 21140 220V	G 1 1/4"	96	63	76	208	175	140	59	16	58	22	11	4,5
M 21120 24V=	M 21120 220V	G 1 1/2"	96	63	76	208	175	140	59	16	58	22	11	4,5

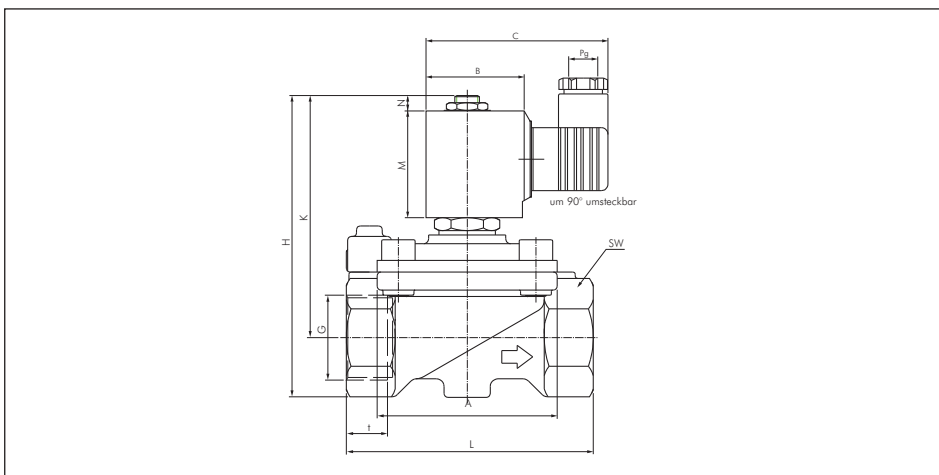

Alle Angaben verstehen sich als unverbindliche Richtwerte! Für nicht schriftlich bestätigte Datenauswahl übernehmen wir keine Haftung. Druckangaben beziehen sich, soweit nicht anders angegeben, auf Flüssigkeiten der Gruppe II bei +20°C.

10. Coils and DIN connectors for solenoid valves

Ersatz-Magnetspulen für 2/2- und 3/2-Wege Magnetventile (Messing)

24V=	12V=	48V=	230V 50Hz	24V 50Hz	115V 50Hz	48V 50Hz	für Ventil
Magnetspulen für 2/2-Wege Magnetventile							
M 224 GB	M 212 GB	---	M 2220 GB	M 22450 GB	nicht tauschbar	---	M 218
M 224 G	M 212 G	M 248 G	M 2220 G	M 22450 G	M 211050 G	M 24850 G	MO 218
M 224 GB	M 212 GB	---	M 2220 GB	M 22450 GB	nicht tauschbar	---	M 214
M 224 G	M 212 G	M 248 G	M 2220 G	M 22450 G	M 211050 G	M 24850 G	MO 214
M 224	M 212	M 248	M 2220	M 22450	M 211050	M 24850	M/MO 238
M 224 G	M 212 G	M 248 G	M 2220 G	M 22450 G	M 211050 G	M 24850 G	M 2380
M 224	M 212	M 248	M 2220	M 22450	M 211050	M 24850	M/MO 212
M 224 G	M 212 G	M 248 G	M 2220 G	M 22450 G	M 211050 G	M 24850 G	M 2120
M 224	M 212	M 248	M 2220	M 22450	M 211050	M 24850	M/MO 234
M 224 G	M 212 G	M 248 G	M 2220 G	M 22450 G	M 211050 G	M 24850 G	M 2340
M 224	M 212	M 248	M 2220	M 22450	M 211050	M 24850	M/MO 210
M 224 G	M 212 G	M 248 G	M 2220 G	M 22450 G	M 211050 G	M 24850 G	M 2100
M 224 D	M 212 D	---	M 2220 D	M 22450 D	M 211050 D	---	MO 2100
M 224 G	M 212 G	M 248 G	M 2220 G	M 22450 G	M 211050 G	M 24850 G	M 2114
M 224 GH	M 212 GH	---	M 2220 GH	M 22450 GH	M 211050 GH	---	MO 2114
M 224 F	M 212 F	---	M 2220 F	M 22450 F	M 211050 F	---	M 21140
M 224 G	M 212 G	M 248 G	M 2220 G	M 22450 G	M 211050 G	M 24850 G	M 2112
M 224 GH	M 212 GH	---	M 2220 GH	M 22450 GH	M 211050 GH	---	MO 2112
M 224 F	M 212 F	---	M 2220 F	M 22450 F	M 211050 F	---	M 21120
M 224 G	M 212 G	M 248	M 2220 G	M 22450 G	M 211050	M 24850	M 220
M 224 GH	M 212 GH	---	M 2220 GH	M 22450 GH	M 211050 GH	---	MO 220
Magnetspulen für 3/2-Wege Magnetventile							
M 224 G	M 212 G	M 248 G	M 2220 G	M 22450 G	M 211050 G	M 24850 G	M/MO 318
M 224 G	M 212 G	M 248 G	M 2220 G	M 22450 G	M 211050 G	M 24850 G	M 314
M 224 GH	M 212 GH	---	M 2220 GH	M 22450 GH	M 211050 GH	---	MO 314



Spulen bei zwangsgesteuerten Ventilen (Druckbereich 0 - ... bar) können nicht zwischen Gleich- und Wechselstrom getauscht werden.

